

TECNOVIDEO

CCTV SYSTEMS AND ACCESSORIES

WP10EXUL SERIES

EXPLOSION PROOF WASHER SYSTEM

- AISI316L STAINLESS STEEL CONSTRUCTION
- UL/C-UL SOLENOID VALVES
- 2.6 GALLONS/10 LITERS RESERVOIR CAPACITY
- EASY INSTALLATION AND MAINTENANCE
- COMPATIBLE WITH THIRD PARTY CAMERAS



TECHNICAL SPECIFICATIONS

GENERAL & MECHANICAL

Dimensions	See drawings next page
Operating Temperature	-20° +55°C (-4° +131°F)
Cabinet material	AISI316L Stainless Steel
Mounting	4 x Ø11mm/0.43in mounting holes
Hose material	Black antistatic polyurethane, UV resistant
Solenoid valve body material	Brass
Max operating pressure	4bar/58PSI
Maximum Delivery head	up to 30m/100ft with 4bar/58PSI pressure
Washing cycles	About 200-500 cycles (depending on camera height, pressure, water level)
Weight	16kg/35Lbs (empty); 26kg/57Lbs (full)
Capacity	10lt/2.6gal
Fluid outlet	10m/33ft hose, 4mm/0.16in bore tube
Cable entry	½" NPT (cable gland not included)

ELECTRICAL

Available supply voltages	24VAC (+/-10%)
Max power consumption	12W

CERTIFICATION

Ingress Protection (NEMA Type)	3, 3S, 4, 4X, 6, 6P, 7 and 9
Solenoid valve:	Class I div 1 Groups B, C and D
CSA/UL	Class II div 1 Groups E, F and G
Cabinet	Not rated
Certified temperature	-40°F to 131°F (-40°C to 55°C) - (CSA to -25°F/-13°C)
EMC	EN 61000-6-2; EN 61000-6-4

MODELS

WP10EXUL01/24	10 Litres tank , Class/Zone certified valve, 24VAC
----------------------	--

MOUNTING ACCESSORIES

APH20EXWP	20m/65ft extension antistatic polyurethane hose
------------------	---

DIMENSIONS

FRONT VIEW

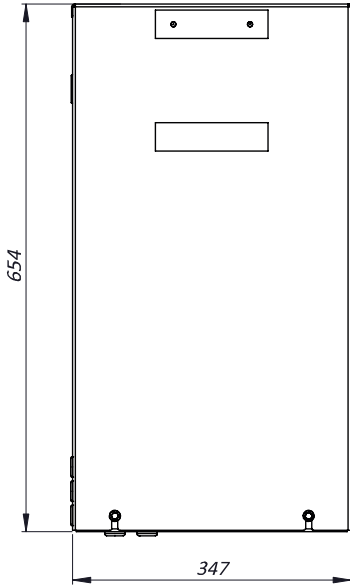

SIDE VIEW

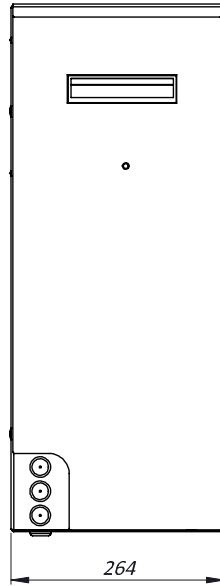

MOUNTING PATTERN

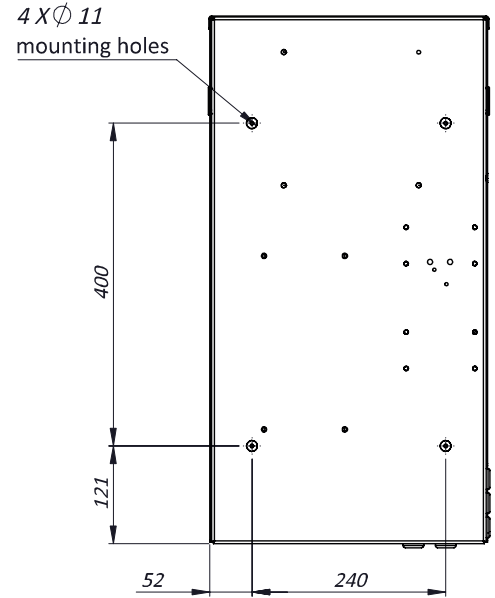

INTERNAL FRONT VIEW

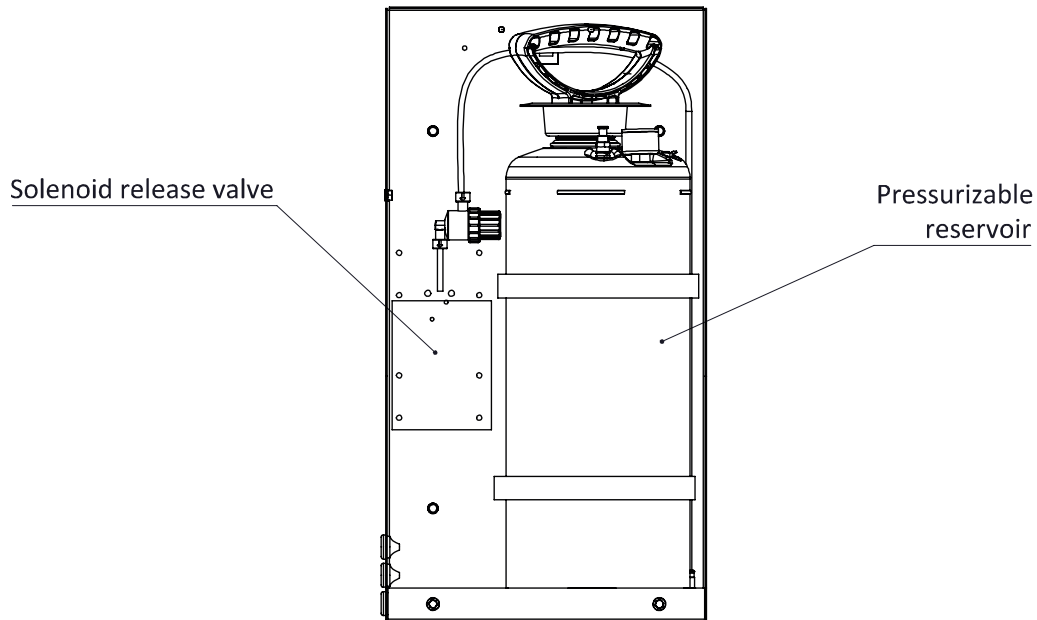

MAX EXTERNAL LENGTH

Model	L1 [mm]	L2 [mm]	L3 [mm]
WP10EXUL01/24	654	347	264