

**DIMENSIONS**

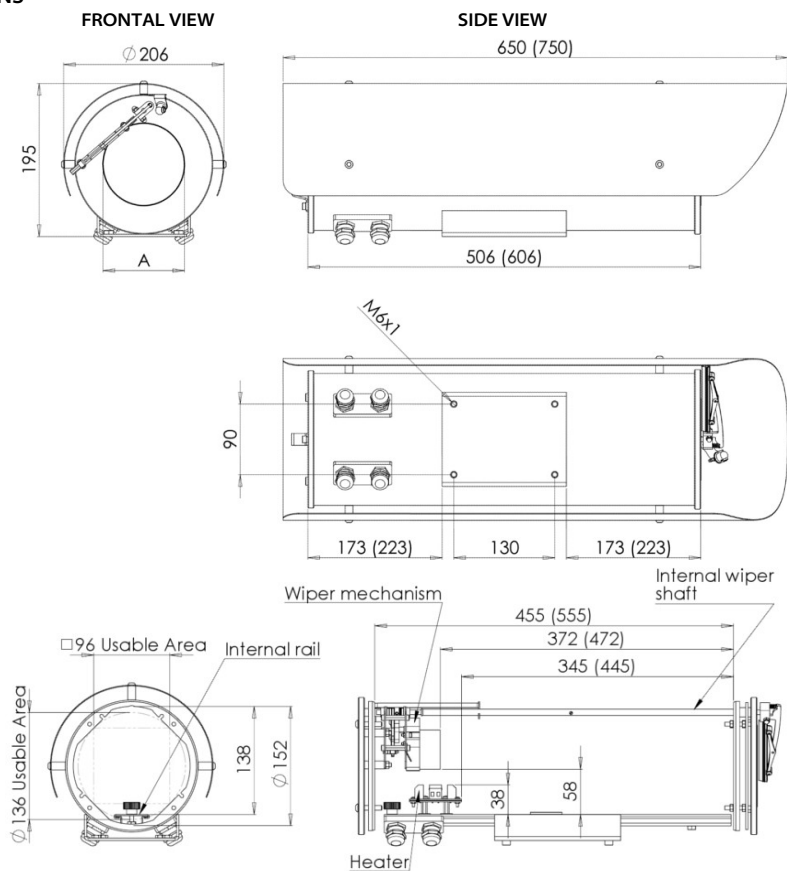

Dimensions in brackets refer to models 168 with 600 mm tube length.

Available measures for "A"

A = 130 mm for 168, 168-L, 168SH and 168SH-L

A = 110 mm for 168IR110 models (germanium window)

A = 104 mm for 168WW and 168WW-L

A = 70 mm for 168IR70 models (germanium window)

Dimensions in millimetres – Tolerances according QM5 – Design and product specifications subject to change without notice

*Preserve this manual as a reference for future needs.*



Used electrical, electronic and stainless steel products should not be mixed with general waste. For proper treatment, recovery and recycling of old products, please take them to applicable collection points, in accordance with your national legislation and the Directives 2002/95/EC and 2002/96/EC. By disposing of these products correctly, you will help to save valuable resources and prevent any potential negative effects on human health and the environment which could otherwise arise from inappropriate waste handling. For more information about collection and recycling of old products, please contact your local municipality or your waste disposal service. Penalties may be applicable for incorrect disposal of this waste, in accordance with national legislation.

**TECNOVIDEO S.r.l.**

Via San L. Murialdo, 8 36030 Villaverla (VI) ITALY

Tel. +39.0445.350444 Fax +39.0445.357259

e-mail: info@tecnovideocctv.com – www.tecnovideocctv.com

# 168 Series

## Medium-Large size Stainless Steel Camera Housing



# Installation manual

**DESCRIPTION**

The **168** series is designed to protect CCTV cameras in outdoor locations, especially where corrosive environment can cause the premature deterioration of a standard aluminium/plastic camera housing, for this purpose the **168** series is constructed entirely from AISI316L stainless steel.

**MODELS**

168*	Housing (Length=500mm)
168-L*	Housing (Length=600mm)
168SH*	Housing (500mm) + Sunshield + Heater
168SH-L*	Housing (600mm) + Sunshield + Heater
168WW**	Housing (500mm) + Sunshield + Heater + Wiper
168WW-L**	Housing (600mm) + Sunshield + Heater + Wiper
168IR70***	Housing (500mm) UW: 70
168IR70-L***	Housing (600mm) UW: 70
168SHIR70***	Housing (500mm) UW: 70 + Sunshield + Heater
168SHIR70-L***	Housing (600mm) UW: 70 + Sunshield + Heater
168WWIR70***	Housing (500mm) UW: 70 + Sunshield + Heater + Wiper
168WWIR70-L***	Housing (600mm) UW: 70 + Sunshield + Heater + Wiper
168IR110***	Housing (500mm) UW: 110
168IR110-L***	Housing (600mm) UW: 110
168SHIR110***	Housing (500mm) UW: 110 + Sunshield + Heater
168SHIR110-L***	Housing (600mm) UW: 110 + Sunshield + Heater
168WWIR110***	Housing (500mm) UW: 110 + Sunshield + Heater + Wiper
168WWIR110-L***	Housing (600mm) UW: 110 + Sunshield + Heater + Wiper

\* Usable front window diameter: 120 mm; thickness 5mm.  
 \*\* Usable front window diameter: 104 mm, thickness 5mm.  
 \*\*\* UW=Usable window diameter; Germanium window, thickness 3 mm, AR/DLC coating.

**INSTALLING THE CAMERA**

	Prior to installation and operation, read carefully this manual of instructions.
	Make sure that the place where the housing will be placed can support the housing in normal operating conditions. Make sure the installation is secure (it must be assured at least the support of 3 times its weight).
	No particular maintenance is needed.
	Operating temperature: -20° +55° C (-4° +131° F).
	Before performing any operation, turn off the power. Only qualified personnel can perform electrical operations according the regulations in force.
	A device must be installed for isolating the appliance from the power supply with a opening distance between the contacts at least of 3 mm). A 0,35/3,5 A (230/24 V) blow fuse must also be installed for protection.
	For connection to the mains, use a multipolar cable having minimum 3x0,75 mm <sup>2</sup> (18 AWG). The main cable must be at least protected by an ordinary PVC sheath.
	Fasten all the cables inside the housing with cables ties or other fixing means to avoid the electrical contact with surrounding parts in case that terminal blocks screw off.

<p>1. Extract the rear flange by removing the four screws and the corresponding washers. Be careful not to lose screws and washers.</p>	
---	--

<p>2. Prepare the housing to install the camera, sliding the upper rail away from the lower rail.</p>	
<p>3. Install the camera on the upper rail using one of the ¼" screws supplied, the plastic washer and one or more spacer to adjust its height position. Then slide the upper rail back on the lower rail into the housing. Perform the electrical and video connections. Cable glands are situated at the bottom of the housing near the rear flange. Tighten the cable glands up to 8 Nm torque ratio. Eventually close the rear flange.</p>	
<p>4. Use the screws at the bottom of the housing to fasten the housing to its apposite support.</p>	
<p><b>5. Only on housings with heater system.</b>                  Perform the input and output (to the camera) voltage connections using the PCB installed inside the housing near the rear flange.</p>	
<p><b>6. Only on housings with wiper system</b>                  Perform wiper electrical connections through the 3 coloured wires connected to the wiper mechanism mounted in the rear flange.</p> <p><b>Model with wiper voltage 110VAC and 240VAC</b></p> <p>Permanent 110VAC or 240VAC voltage must be connected between WHITE wire (GND) and the BLUE wire (line).                  To activate the wiper, connect the GREEN wire to the BLUE. A normally open external switch, connected between GREEN and BLUE, can be used for this operation.                  When the voltage is connected to the GREEN wire, the wiper works and continues to work until the voltage is disconnected, then wiper parks itself to its initial position.</p> <p><b>Model with wiper voltage 24VAC or 24 VDC</b></p> <p>Permanent 24VAC or 24VDC (depending on model) voltage must be connected between the GREEN wire (line) and the GREY wire (neutral/GND) of the terminal block.                  To activate the wiper, connect the GREY wire (neutral/GND) to the BLUE wire. A normally open switch, connected between GREY and BLUE, can be used for this operation.                  When the BLUE wire is connected to the GREY wire (neutral/GND), the wiper works and continues to work until the wire is disconnected, then it parks itself to its initial position.</p>	

The manufacturer is not to be held responsible for any damage resulting from failure to observe the installation standards and the instructions contained in the present manual.

The descriptions and illustrations contained in the present manual are not binding. The manufacturer reserves the right to make any alterations deemed appropriate for the technical, manufacturing and commercial improvement of the product, while leaving the essential product features unchanged, at any time and without undertaking to update the present publication.

The manufacturer declines all responsibility for any consequences resulting from improper use of the product, or use which is different from that expected and specified in the present documents.