

101C Series

Small size Stainless Steel Camera Housing with ceiling mounting bracket



Preserve this manual as a reference for future needs.



Used electrical, electronic and stainless steel products should not be mixed with general waste.
For proper treatment, recovery and recycling of old products, please take them to applicable collection points, in accordance with your national legislation and the Directives 2002/95/EC and 2002/96/EC.
By disposing of these products correctly, you will help to save valuable resources and prevent any potential negative effects on human health and the environment which could otherwise arise from inappropriate waste handling.
For more information about collection and recycling of old products, please contact your local municipality or your waste disposal service.
Penalties may be applicable for incorrect disposal of this waste, in accordance with national legislation.

The manufacturer is not to be held responsible for any damage resulting from failure to observe the installation standards and the instructions contained in the present manual.

The descriptions and illustrations contained in the present manual are not binding. The manufacturer reserves the right to make any alterations deemed appropriate for the technical, manufacturing and commercial improvement of the product, while leaving the essential product features unchanged, at any time and without undertaking to update the present publication.

The manufacturer declines all responsibility for any consequences resulting from improper use of the product, or use which is different from that expected and specified in the present documents.

TECNOVIDEO S.r.l.

Via San L. Murialdo, 8 36030 Villaverla (VI) ITALY
Tel. +39.0445.350444 Fax +39.0445.357259
e-mail: info@tecnovideocctv.com – www.tecnovideocctv.com

Installation manual

DESCRIPTION



The **101-ceiling series** camera housing is constructed entirely from AISI316L stainless steel, for use in industrial and marine environments and in general where a corrosive atmosphere can cause a rapid deterioration of a standard aluminium-steel housing.

The 101-ceiling series housing is composed by a cylindrical body closed by two covers: the front window cover (that is fixed and doesn't have to be removed) and the rear cover that is attached to the ceiling mounting bracket. For all models, a thermostatically controlled heater is available as optional.

MODELS

101C	Housing length=120mm with sunshield
101C-L	Housing length=200mm with sunshield
101CIR50	Housing length=120mm with sunshield and 50mm germanium window
101CIR50-L	Housing length=200mm with sunshield and 50mm germanium window
101CIR70	Housing length=120mm with sunshield and 70mm germanium window
101CIR70-L	Housing length=200mm with sunshield and 70mm germanium window

INSTALLING THE CAMERA

	Prior to installation and operation, read carefully this manual of instructions.
	Make sure that the place where the housing will be placed can support the housing in normal operating conditions. Make sure the installation is secure (it must be assured at least the support of 3 times its weight).
	No particular maintenance is needed.
	Operating temperature: -20° +55° C (-4° +131° F).
	Before performing any operation, turn off the power. Only qualified personnel can perform electrical operations according to the regulations in force.
	A device must be installed for isolating the appliance from the power supply with a opening distance between the contacts at least of 3 mm). A 0,2/2 A (230/24 V) blow fuse must also be installed for protection.
	For connection to the mains, use a multipolar cable having minimum 3x0,75 mm ² (18 AWG). The main cable must be at least protected by an ordinary PVC sheath.
	Fasten all the cables inside the housing with cables ties or other fixing means to avoid the electrical contact with surrounding parts in case that terminal blocks screw off.

- Once a proper position for the housing has been located, fix the housing's bracket to the ceiling using suitable screws.
- Once the housing's bracket is firmly fixed to the ceiling, remove the sunshield by unscrewing (not completely, using the key supplied) the three sunshield's screws and remove the sunshield, sliding it forward and pulling it up.
- Open the housing, unscrewing the housing cylindrical body from the rear flange. To do this operation, hold the cylindrical body with hands and rotate it anticlockwise. **DO NOT REMOVE** the front window cover.
- Mount the camera on the internal rail using the 1/4" screw supplied. Feed the cables through the cable gland and make the electrical and video connections. Tighten the cable gland up to a 8 Nm torque ratio. A single cable with power and coaxial together is recommended.

- Close the housing, screwing back the housing cylindrical body on the rear flange. Make sure the O-ring seal is fitted in its position on the rear flange.
- Fit the housing in the desired position, and tighten the swivel joint screws.

DIMENSIONS

FRONTAL VIEW

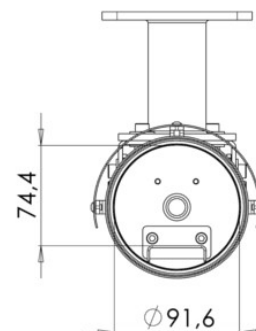

SIDE VIEW

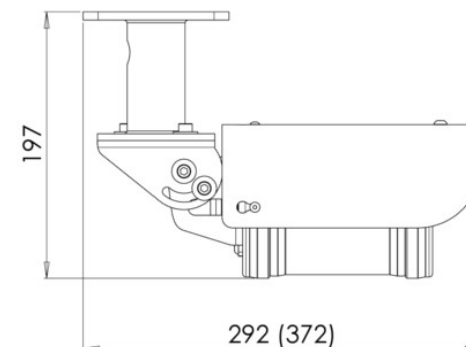

101C: Housing with ceiling mounting bracket (dimensions in brackets refer to model 101C-L)

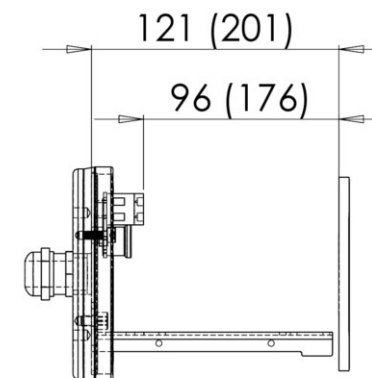

Internal dimensions

Dimensions in millimetres – Tolerances according QMS – Design and product specifications subject to change without notice