

Stainless Steel P&T Unit

# VSPT250

AISI316L Stainless Steel construction  
For use in highly corrosive environments  
Maximum Load 25 kg  
Variable Speed  
Weatherproof standard IP67  
Pre-set positioning fitted as standard



■ VSPT250  
Variable Speed Pan & Tilt Unit

- A reliable Pan & Tilt unit is a key feature in video surveillance systems which need to video a wide or a dynamic location. This is why the VSPT250 Pan & Tilt unit is the best choice, especially for Offshore, Marine, Heavy and Food Industry and for every situation where corrosive agents may rapidly damage standard aluminum-steel units. The VSPT250 Pan & Tilt Unit is made up by a AISI316L stainless steel cylindrical body with three end covers. Inside the cylindrical body, the Pan and Tilt Drive Motors are integrated with control and interconnection PCB. VSPT250 internal parts are made in AISI316L Stainless Steel or aluminum.

The VSPT250 Pan & Tilt Unit can handle up to 25 kg loads. It also has switches to electronic adjust limits and rugged high torque motors. This grant a long operational life. The pre-set positioning of the unit is controlled by potentiometers fitted as standard on pan and tilt axis. A VSPT250 extra feature is the possibility to manually set the rotation angle.

VSPT250 is suitable for 129, 168 and 204 camera housings.

Mounting brackets entirely made in AISI316L stainless steel are available.



■ VSPT250+129WW+SSBK250  
Housing with Pan & Tilt unit and mounting bracket

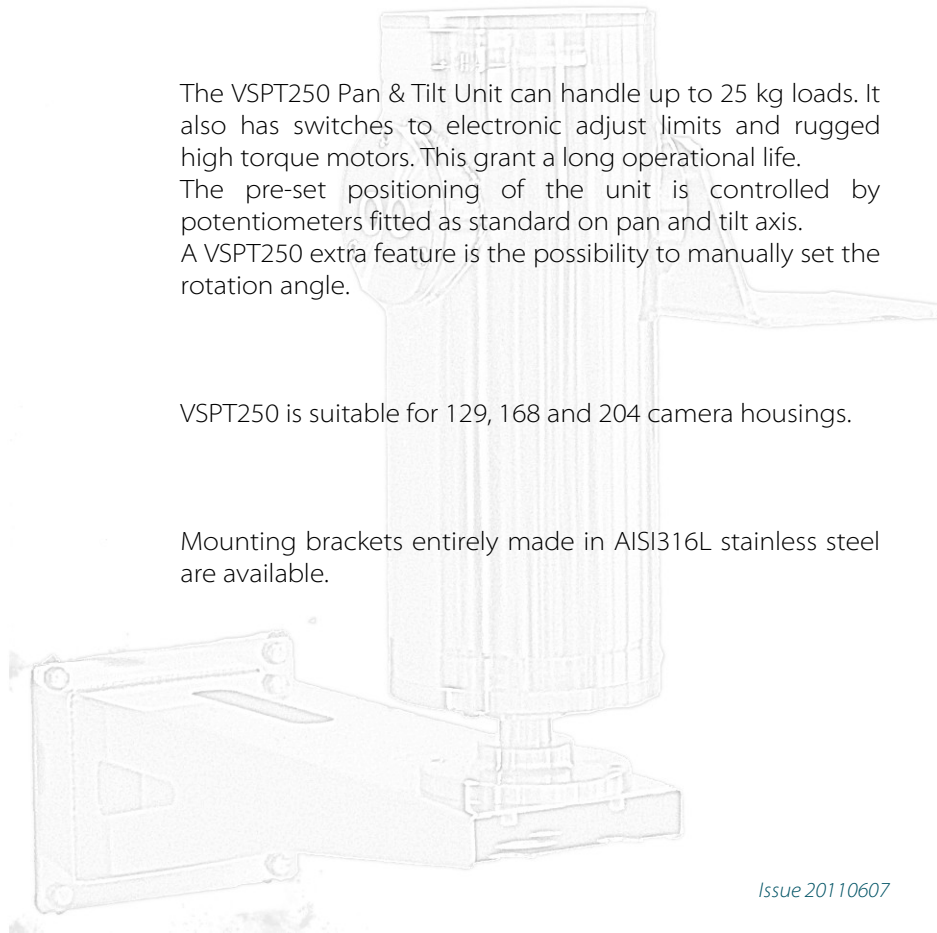

# Technical Specifications

## MODELS

**VSPT250** P&T unit, 24 VDC motors

## GENERAL & MECHANICAL

**Construction:** AISI316L Stainless Steel  
**Finish:** Electro-polished

**Pan Angle:** 350° Max  
**Pan Speed:** 0 – 18°/second  
**Pan Torque:** 80 Nm (in both ways)

**Tilt Angle:** 350° Max  
**Tilt Speed:** 0 – 9,5°/second  
**Tilt Torque:** 107 Nm (in both ways)

**Backlash:** <0.1°

**Maximum load:** 25 kg

**Weight:** 17,5 kg

**Mounting:** 4xM8 on 101.6 mm PCD

**Pre-set Positioning:** Fitted as Standard

### Rotation Angle Manually Set

**Seals:** 'O' Ring

### Cable entries:

2 M20x1,5 nickel plated brass cable glands (included).

Standard cable diameter 6-10mm, upon request cable diameter 8-12mm. Different cable entries are available to meet every installation requirement.

## CERTIFICATION

**Rating:** IP67  
**Ambient Temperature Range:** -20° to +55° C

## ELECTRICAL

**Voltage:** 24 VDC  
**Power consumption:** 25 W per Motor

## MOUNTING ACCESSORIES

**SSBK250** AISI316L Stainless Steel wall mounting bracket

**SSPM250** AISI316L Stainless Steel pole mount adapter

## SUITABLE CAMERA HOUSINGS

**129 Series** medium stainless steel camera housings

**168 Series** medium-large stainless steel camera housings

**204 Series** large stainless steel camera housings



# Dimensions

**SIDE VIEW**

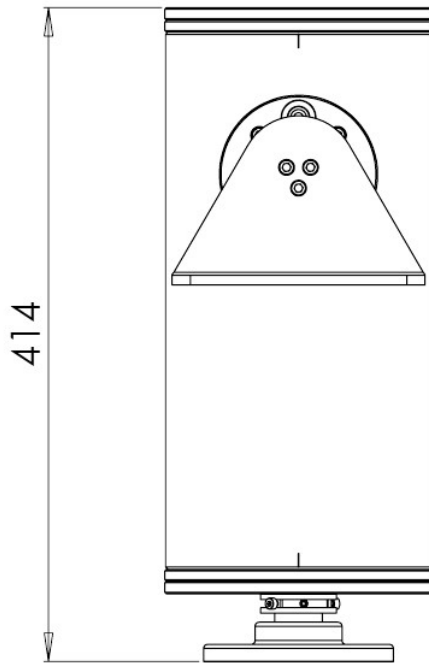

**FRONTAL VIEW**

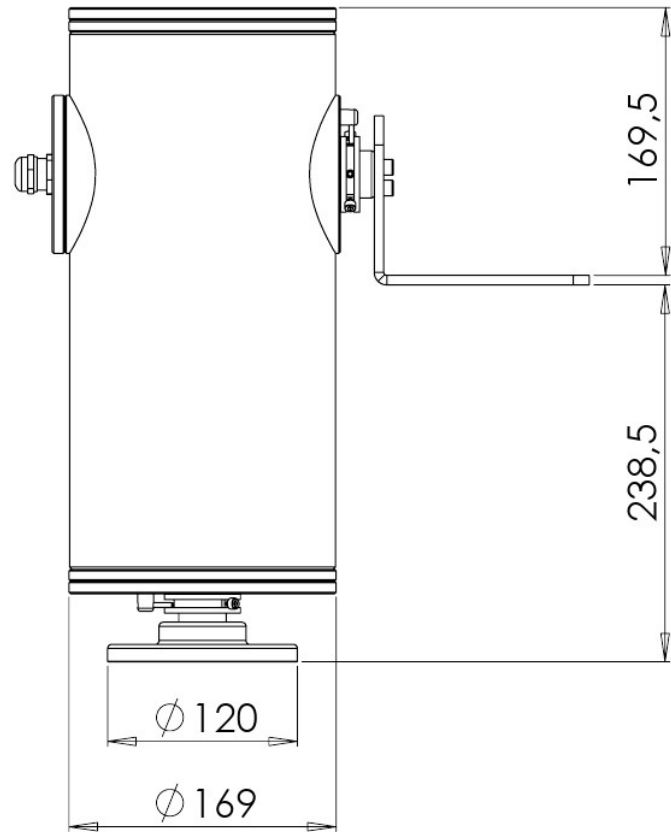

**BOTTOM VIEW**

